



U17

Machine Weight: (Rubber track/Steel track) 1720/1800 kg

Bucket capacity: 0.05 m³

Engine power: 11.8/2300 kW/rpm

CE

- Kubota engine Strong power,
- Excellent uphill performance
- High efficiency and low fuel consumption
- Telescopic chassis, solid and reliable
- Swiftly detachable canopy
- Easy maintenance
- Standard with Rubber Tracks

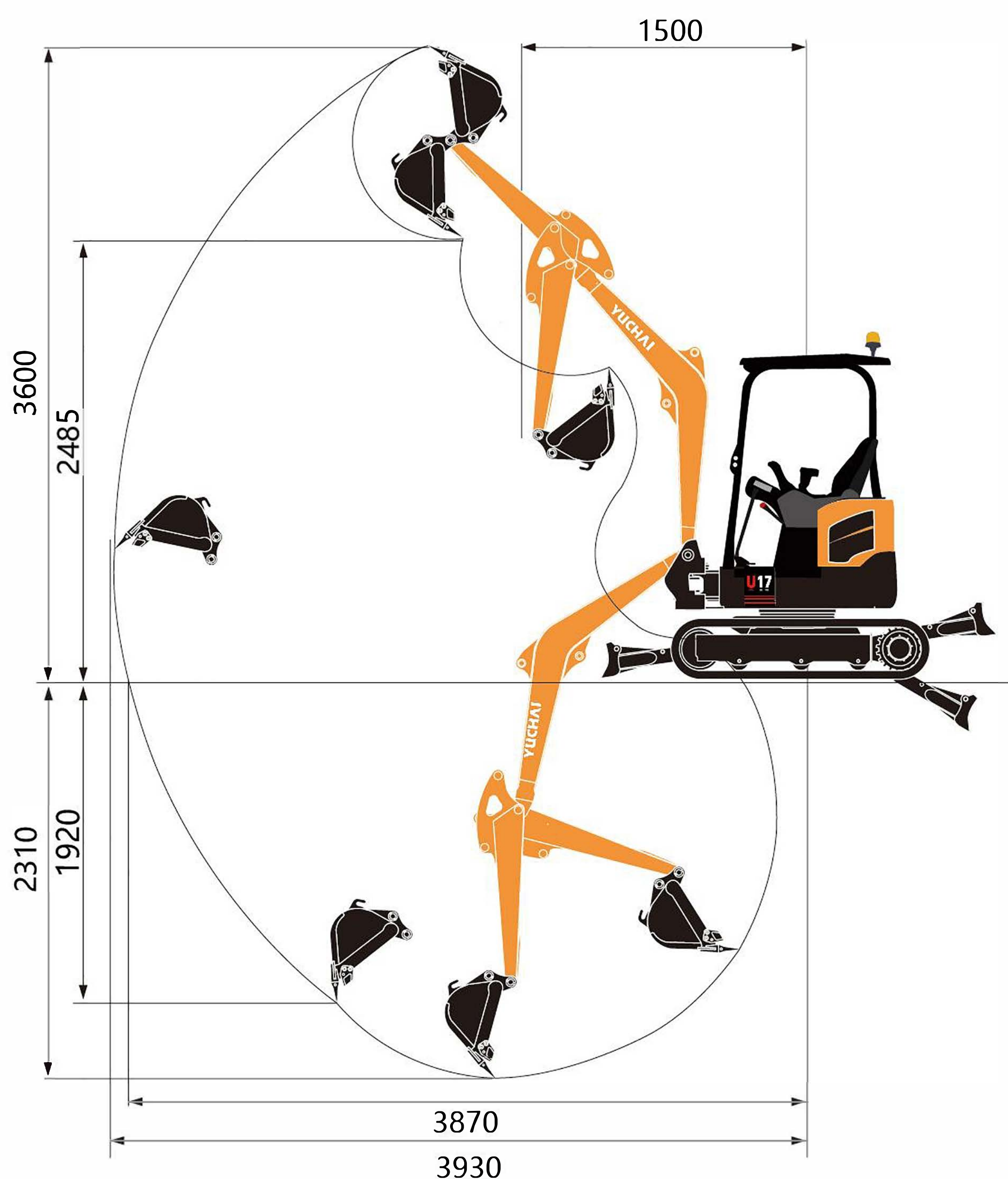
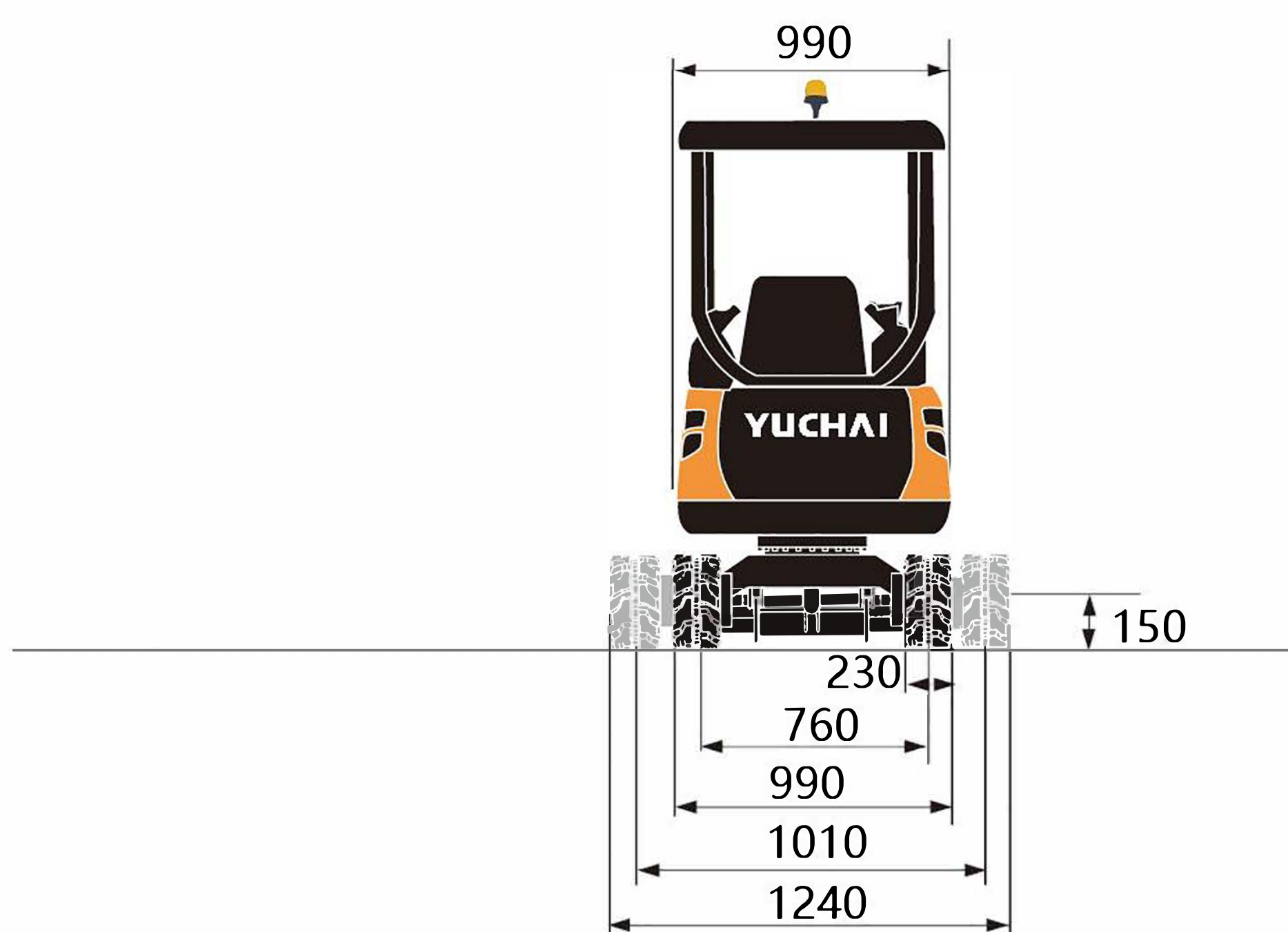
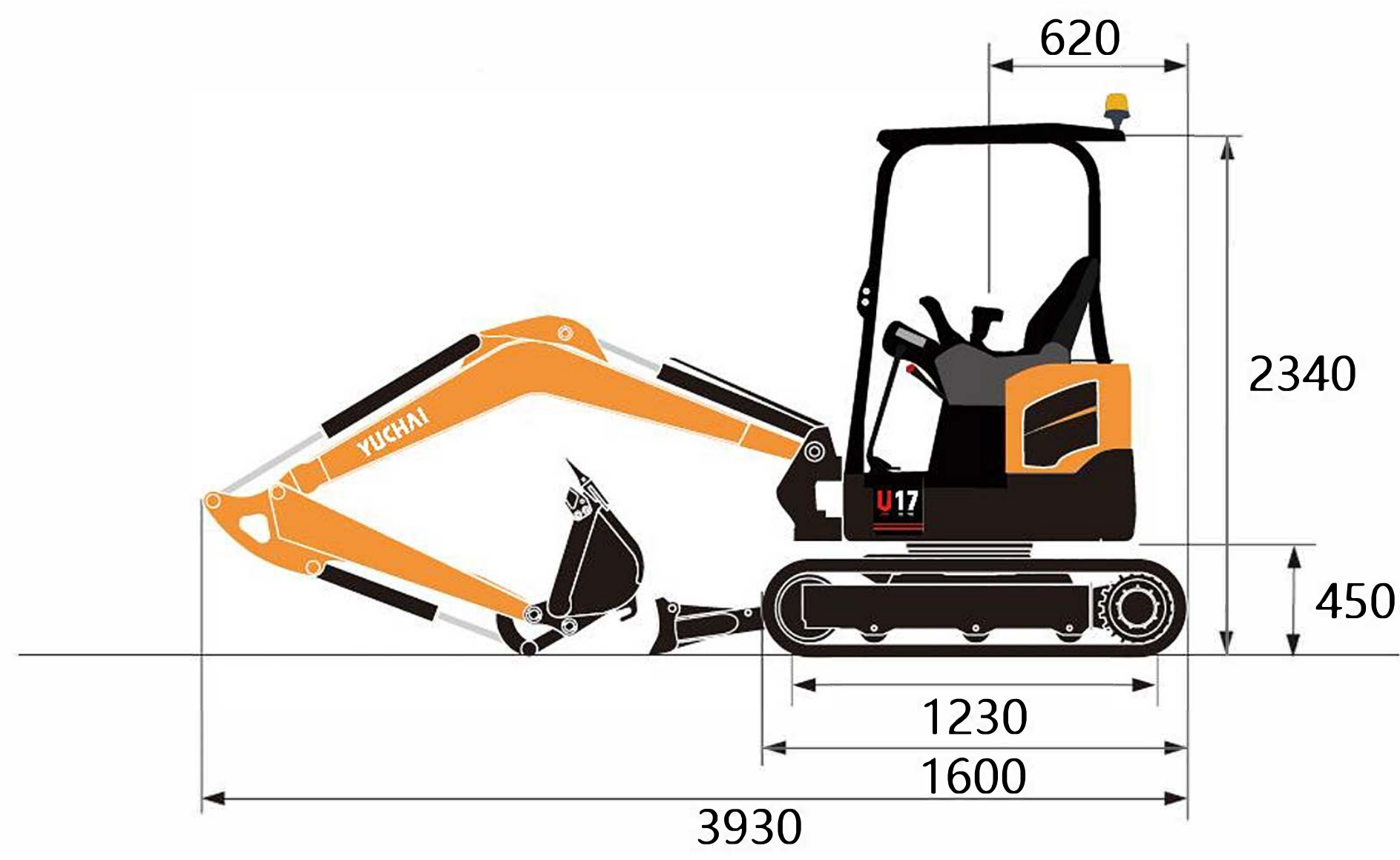

► Technical Specification

Basic parameter

Machine weight	1720 kg
Bucket capacity	0.05 m ³
Width of bucket	470 mm

Performance parameter

Engine model	Kubota D902-E4B
Engine power	11.8/2300 kW/rpm
Max. Gradeability	30 °
Max. digging force of arm	9.5 kN
Max. digging force of bucket	17.2 kN
Traveling speed	2/4 km/h
Max. hauling force	25 kN
Slewing speed of platform	8.5~10.5 rpm

Operating parameter

Max. digging height	3600 mm
Max. digging depth	2310 mm
Max. digging radius	3930 mm
Max. digging radius on ground level	3870 mm
Max. dumping height	2485 mm
Min. slewing radius	1500 mm
Max. vertical digging depth	1920 mm

Transportation dimension

Overall length	3930 mm
Overall width	990 mm
Overall height	2340 mm

Other Parameter

Width of undercarriage	990/1240 mm
Length of track	1600 mm
Width of track	230 mm
Height between undercarriage and ground	150 mm
Height between platform and ground	450 mm
Platform tail turning radius	620 mm
Length to center of rollers	1230 mm
Fuel tank capacity	16 L
Hydraulic oil tank capacity	16 L
Track gauge	760/1010 mm
Working Pressure	24 Mpa
Arm length	950 mm
Boom length	1828 mm
Steering head angle	60°(L)/55°
Flow rate	64.4 L/Min

Ratels AB
 Address: Oxelgrensvägen 33, 152 42 Södertälje
 Tel: 0046 (0)8301212
 Email: info@ratelsimport.se
 Website: www.ratelsimport.se

Specifications are subject to change without prior notice